

**WAGNER**

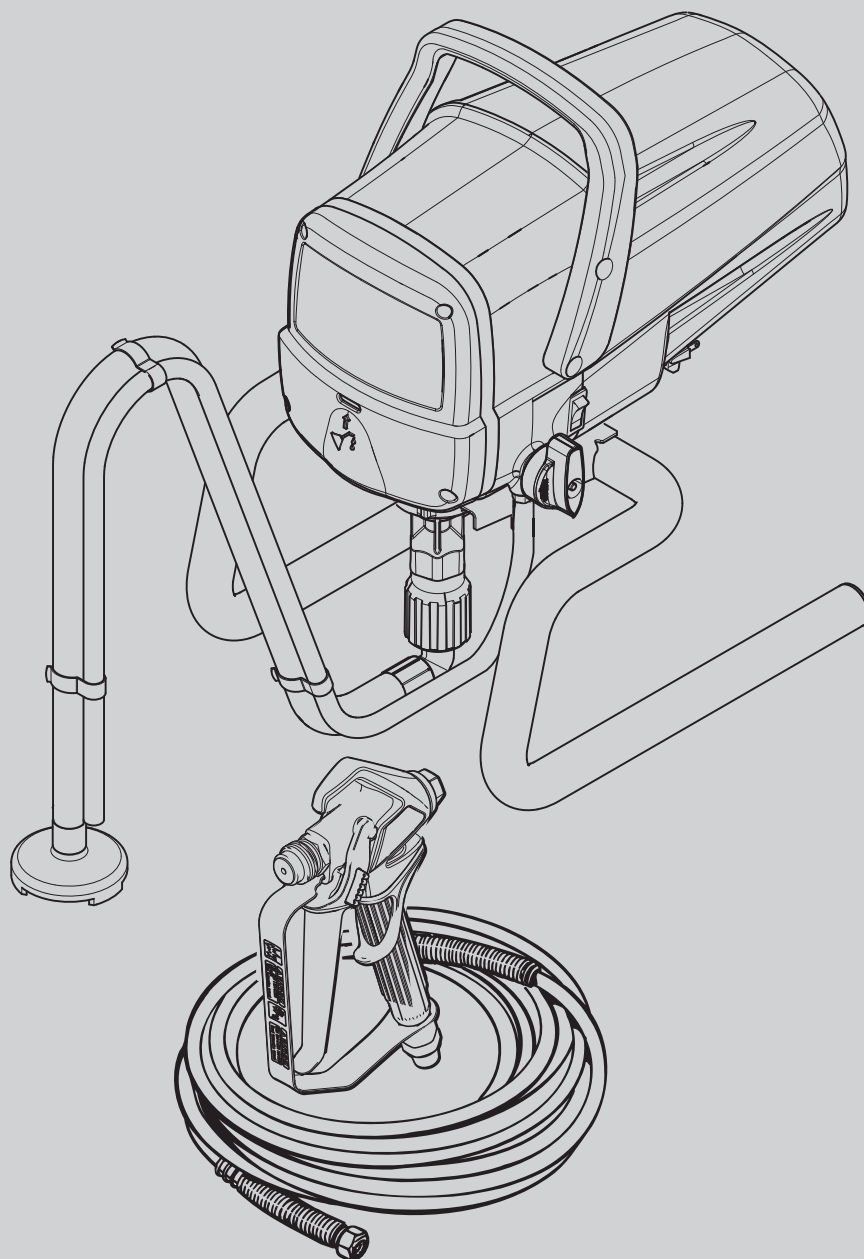

## **POWERPAINTER 90 EXTRA SKID**

### **ORIGINAL- BETRIEBSANLEITUNG**



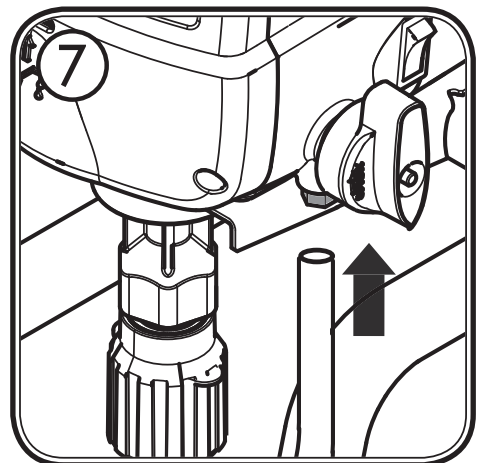
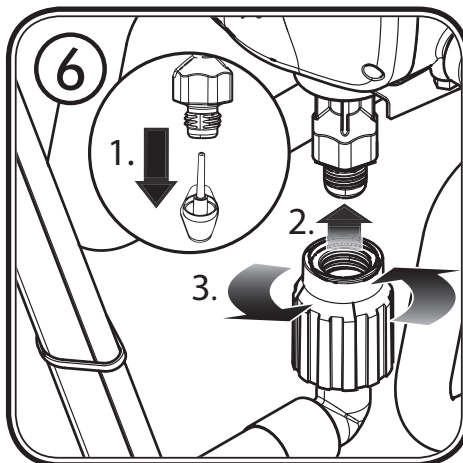
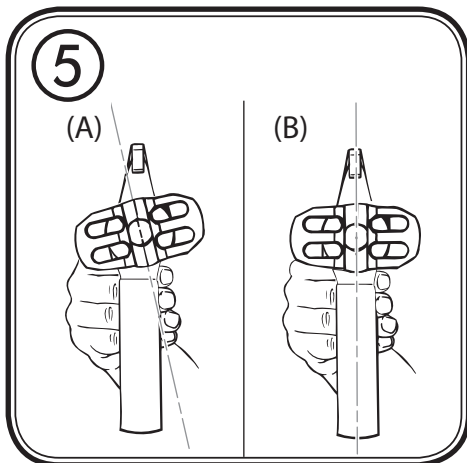
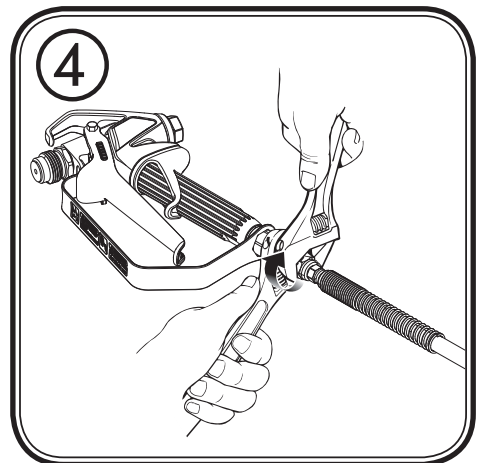
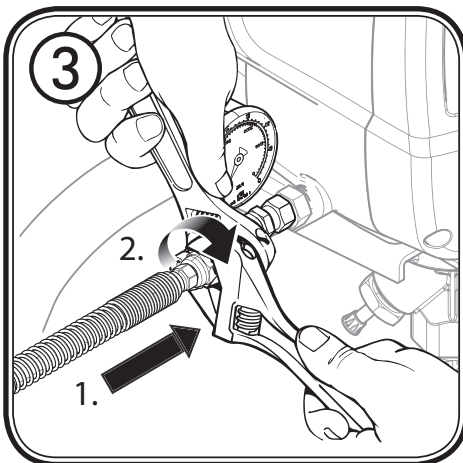
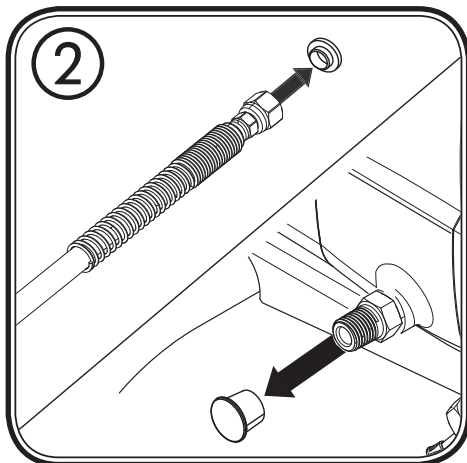
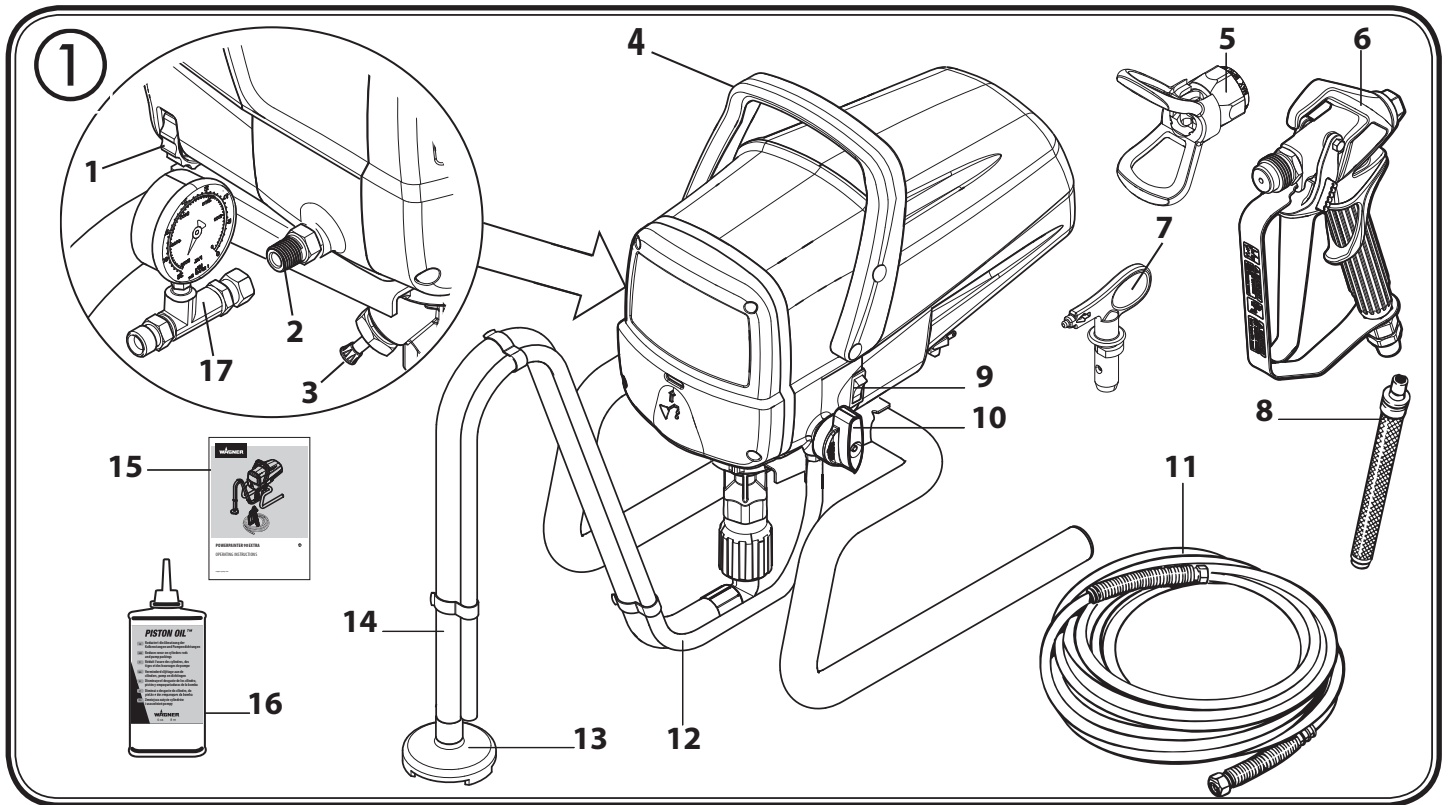

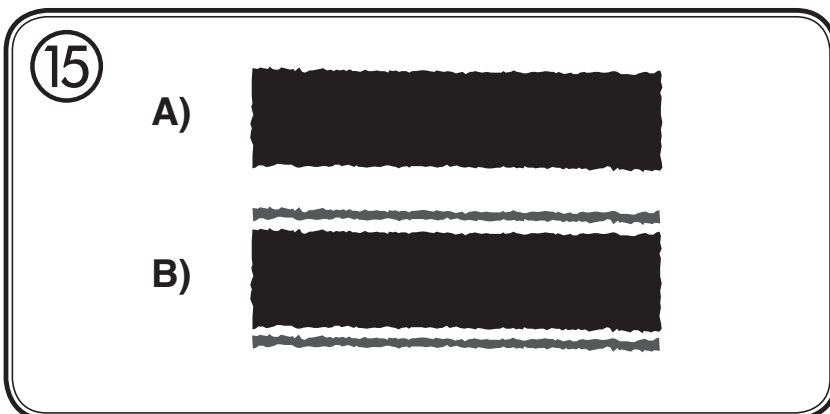
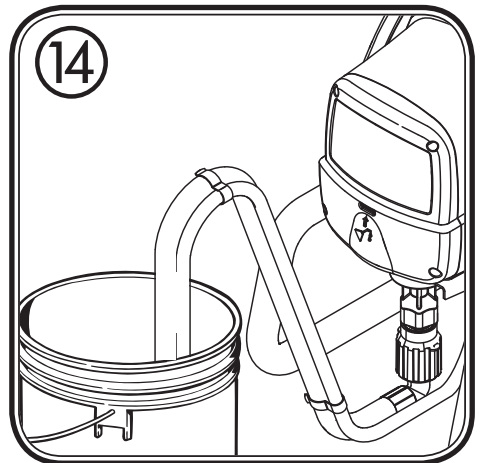
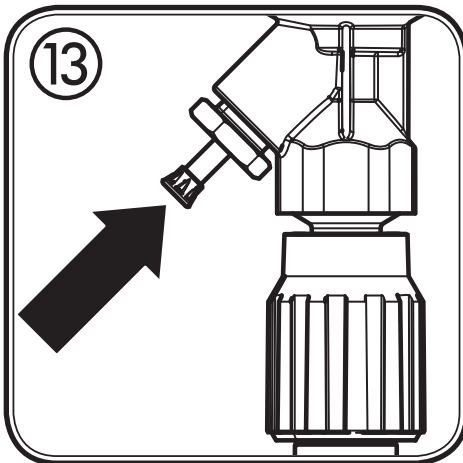
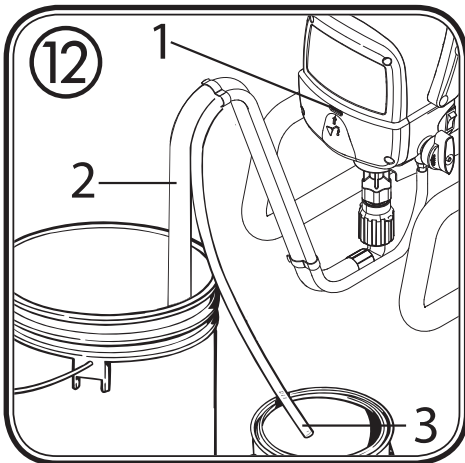
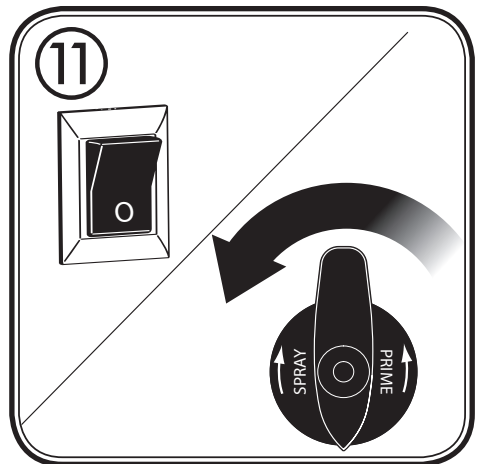
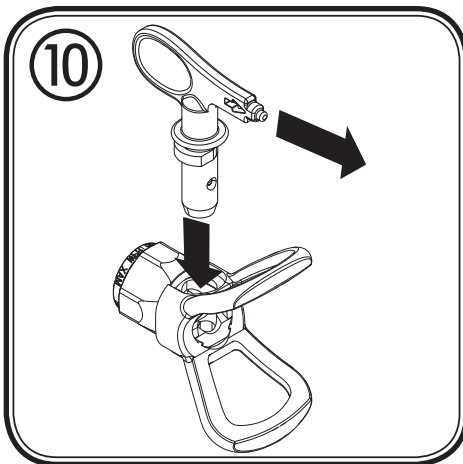
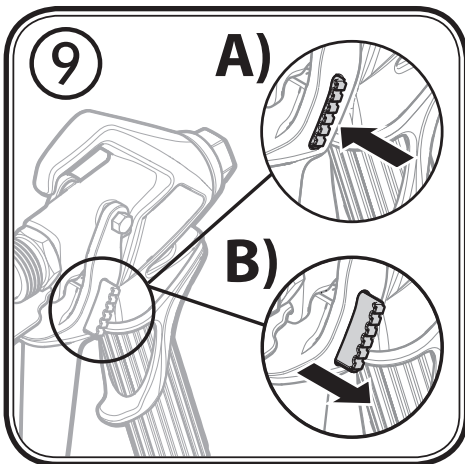
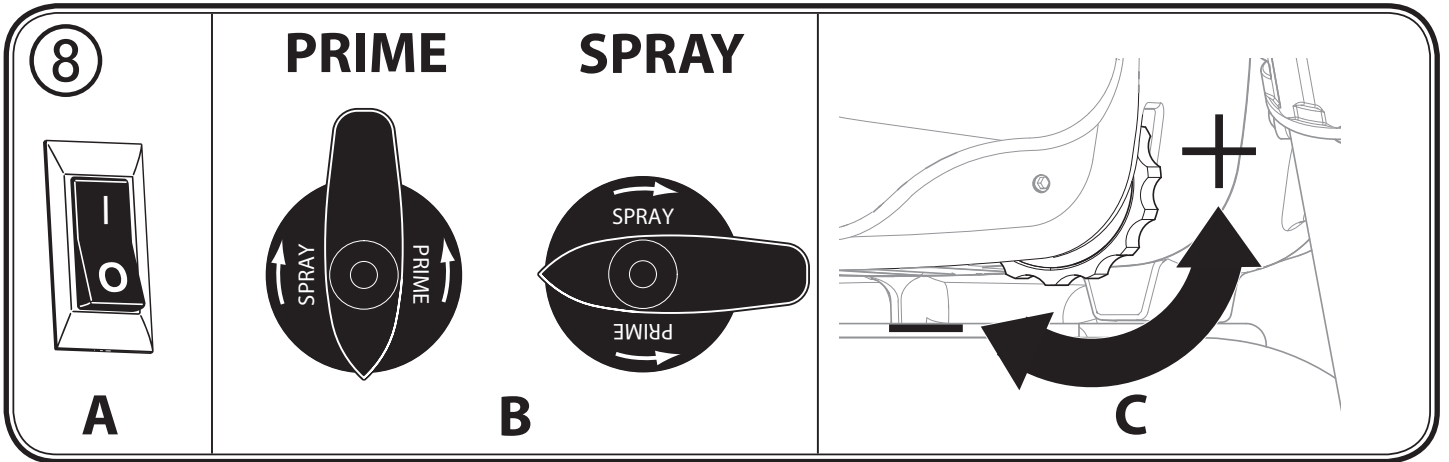

16

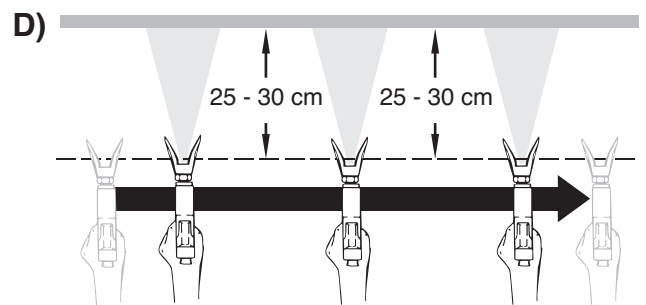
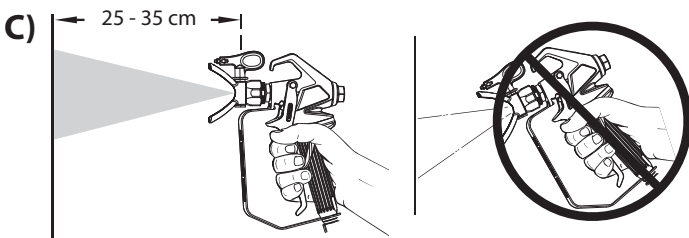
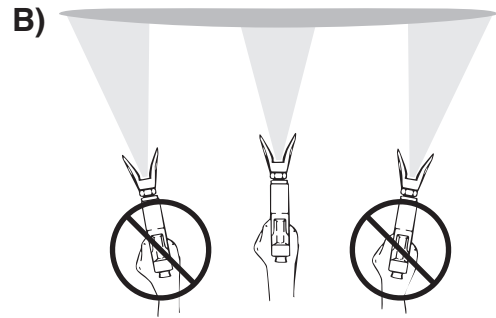
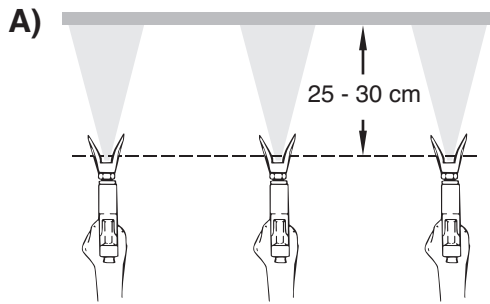

17

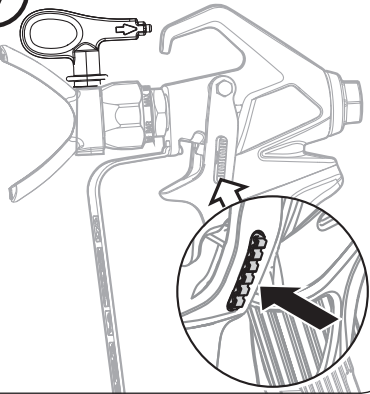

18

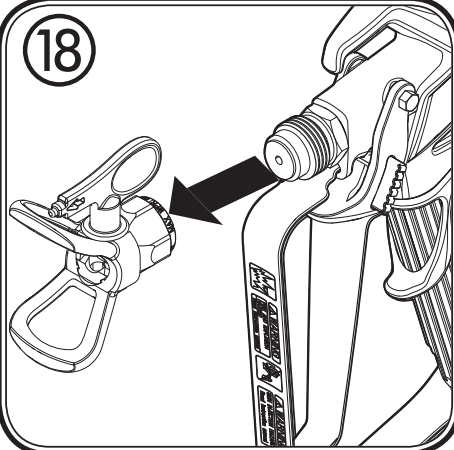

20

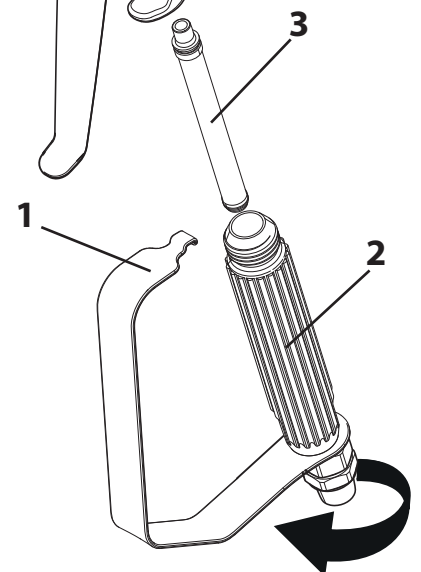

19

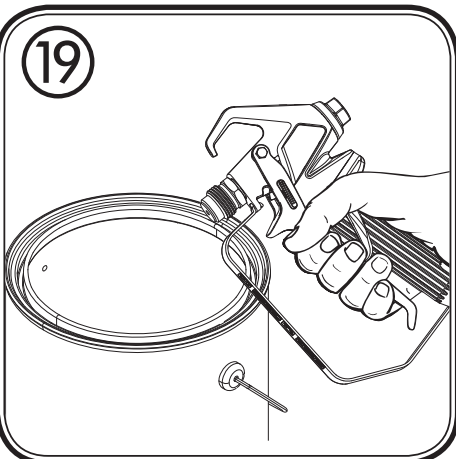

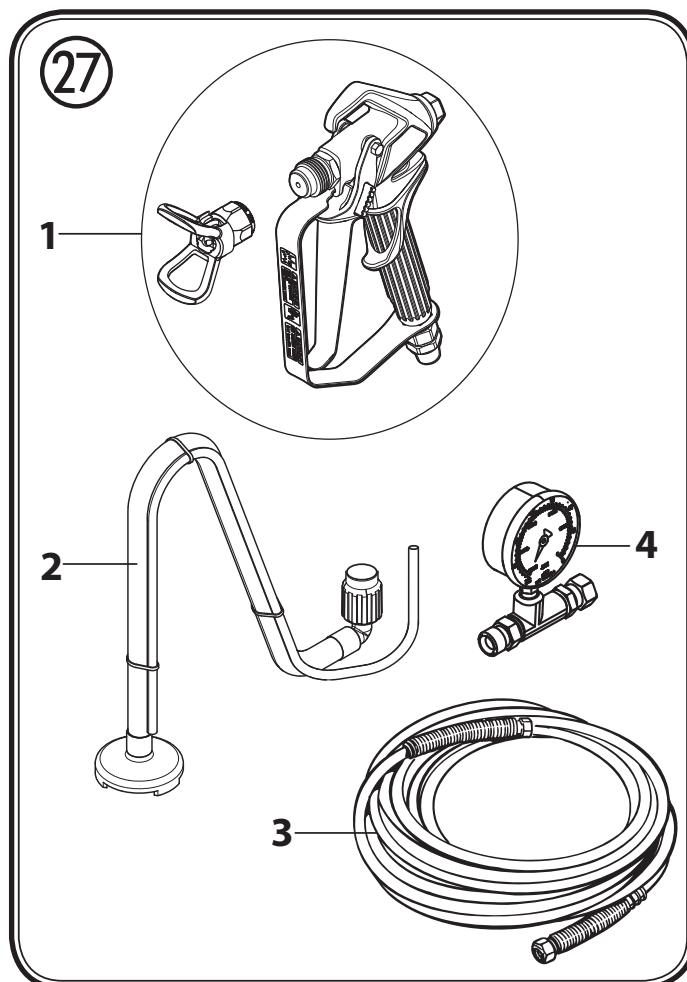
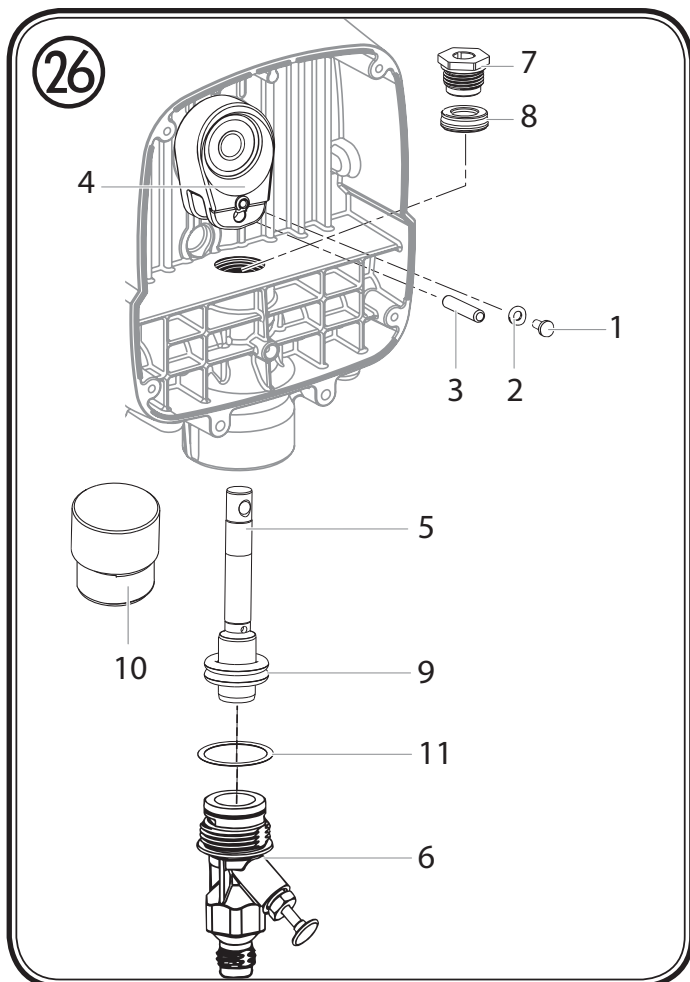
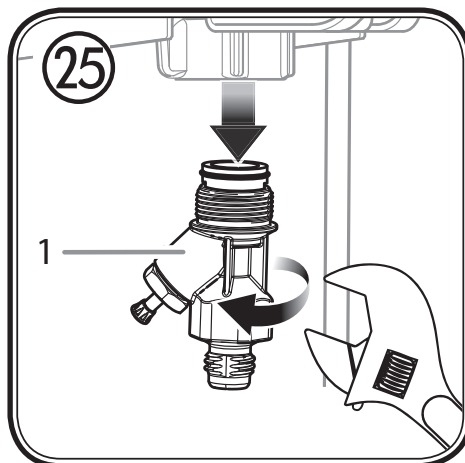
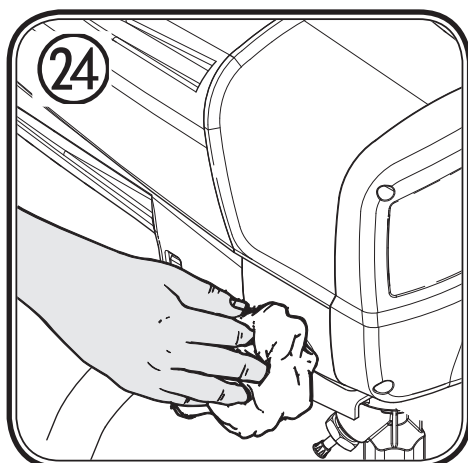
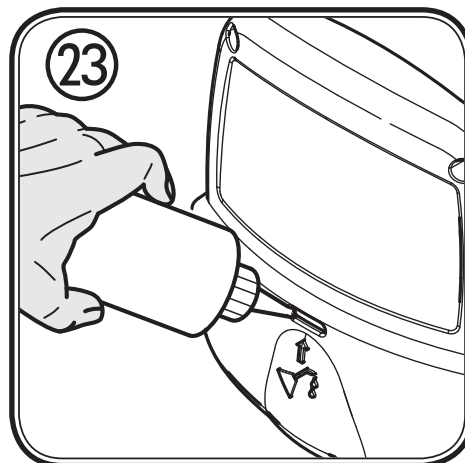
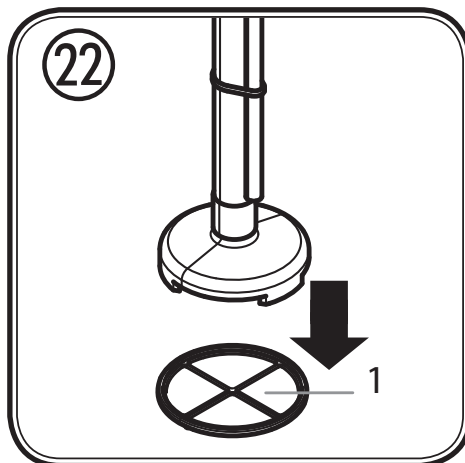
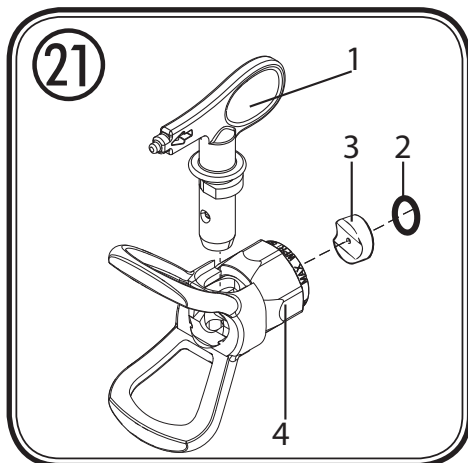

Translation of the original operating instructions

# Warning!

**Attention: Danger of injury by injection!**  
Airless units develop extremely high spraying pressures.

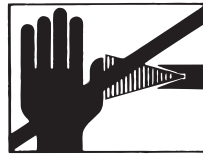

**Danger**

**1**

Never put your fingers, hands or any other parts of the body into the spray jet!  
Never point the spray gun at yourself, other persons or animals.  
Never use the spray gun without safety guard.

Do not treat a spraying injury as a harmless cut. In case of injury to the skin through coating materials or solvents, consult a doctor immediately for quick and expert treatment. Inform the doctor about the coating material or solvent used.

**2**

The operating instructions state that the following points must always be observed before starting up:

1. Faulty units must not be used.
2. Secure spray gun using the safety catch on the trigger.
3. Ensure that the unit is properly earthed. The connection must take place through a correctly earthed two-pole and earth socket outlet.
4. Check allowable operating pressure of high-pressure hose and spray gun.
5. Check all connections for leaks.

**3**

The instructions regarding regular cleaning and maintenance of the unit must be strictly observed.

Before any work is done on the unit or for every break in work the following rules must be observed:

1. Release the pressure from spray gun and hose.
2. Secure the spray gun using the safety catch on the trigger.
3. Switch off unit.





## Be safety-conscious !



**Congratulations on your purchase of a WAGNER colour application device.**

You have purchased a proprietary device that requires careful cleaning and care to ensure trouble-free functioning. **Read the operating instructions carefully before using the tool and observe the safety instructions. Keep the operating instructions in a safe place.**

**Explanation of symbols used**

 Danger	Indicates an immediate danger. Unless avoided, death or serious injuries will result.
	Indicates tips for use and other particularly useful information.
	Wear suitable ear protection when working.
	Wear suitable respiratory equipment when working.
	Wear suitable safety gloves when working.

**General Safety Instructions**

**Warning!** *Read all safety notifications and instructions. Failure to comply with the safety notifications and instructions provided may result in electric shock, fire and/or serious injury. The term "power tool" used below covers both mains-operated power tools (with mains lead) and accumulator-operated power tools (without mains lead).*



**1. Safety at the workplace**

- a) **Keep your workplace clean and well lit.** *Disorder or unlit workplaces may result in accidents.*
- b) **Never use the tool in hazardous areas that contain flammable liquids, gases or dusts.** *Power tools generate sparks that can ignite the dust or vapors.*
- c) **Keep children and other persons away when using the power tool.** *You can lose control of the tool if you are distracted.*

**2. Electrical Safety**

- a) **The tool plug must fit into the socket. The plug may not be modified in any form. Do not use adaptor plugs together with protective-earthed tools.** *Unmodified plugs and suitable sockets reduce the risk of an electric shock.*
- b) **Avoid physical contact with earthed surfaces such as pipes, heating elements, stoves and refrigerators.** *The risk through electric shock increases if your body is earthed.*
- c) **Keep the equipment away from rain and moisture.** *The risk of an electric shock increases if water penetrates electrical equipment.*
- d) **Do not misuse the mains lead by carrying the tool by the lead, hanging it from the lead or by pulling on the lead to remove the plug. Keep the lead away from heat, oil, sharp edges or moving tool parts.** *Damaged or twisted leads increase the risk of an electric shock.*
- e) **If you work outdoors with a power tool, only use extension cables suitable for outdoor use.** *The use of an extension lead that is suitable for outdoors reduces the risk of an electric shock.*
- f) **If you cannot avoid using the tool in a damp environment, use a residual current operated circuit-breaker.** *Using a residual current operated circuit-breaker avoids the risk of electric shock.*

### 3. Safety of Persons

- a) **Be attentive. Pay attention to what you are doing and work sensibly with a power tool. Do not use the tool if you are tired or under the influence of drugs, alcohol or medication.** *Just a moment of inattentiveness while using the tool can lead to serious injuries.*
- b) **Wear personal safety equipment and always wear safety goggles.** *Wearing personal protective equipment, such as dust mask, non-slip safety shoes, safety helm or ear protection, depending on the type of power tools, reduces the risk of injury.*
- c) **Avoid accidental starting-up. Ensure that the switch is in the "OFF" position before inserting the plug into the socket.** *Accidents can occur if you carry the power tool while your finger is on the switch or if you connect the power tool to the power supply which it is on.*
- d) **Remove setting tools or wrenches before switching on the power tool.** *A tool or wrench that is in a rotating tool part can lead to injuries.*
- e) **Avoid an unnatural posture. Ensure that you are standing securely and have your balance at all times.** *This ensures that you can control the tool better in unexpected situations.*
- f) **Wear suitable clothing. Do not wear wide clothing or jewelry. Keep your hair, clothes and gloves away from moving parts.** *Loose clothing, jewelry or long hair can be caught in moving parts.*
- g) **Do not lull yourself into a false sense of security and do not think yourself above the safety rules for electric tools, even if you are familiar with the electric tool following extensive practical experience.** *Careless use can lead to serious injuries in fractions of a second.*

### 4. Careful Handling and Use of Power Tools

- a) **Do not overload the tool. Use the power tool designed for the work that you are doing.** *You work better and safer in the specified performance range if you use the suitable power tool.*
- b) **Do not use power tools whose switch is defective.** *A power tool that cannot be switched on or off is dangerous and has to be repaired.*
- c) **Remove the plug from the socket before carrying out tool settings, changing accessories or putting the tool away.** *This precautionary measure prevents unintentional starting of the tool.*
- d) **Store unused power tools so that they are inaccessible to children. Do not let persons use the tool who are not familiar with it or who have not read these instructions.** *Power tools are dangerous when they are used by inexperienced persons.*
- e) **Take proper care of your tools. Check whether the moving parts function trouble-free and do not jam, whether parts are broken or damaged so that the tool function is impaired.** *Have damaged parts repaired before using the tool. Many accidents have their origin in power tools that have been maintained badly.*
- f) **Use the power tool, accessories, insert tools, etc. in accordance with these instructions and in a fashion specified for this special tool type. Take the working conditions and the activity to be carried out into consideration.** *The use of power tools for purposes other than the intended ones can lead to dangerous situations.*
- g) **Keep the handles and grip surfaces dry, clean and free of oil and grease.** *Slippery handles and grip surfaces hamper safe operation and control of the electric tool in unforeseen situations.*

### 5. Service

- a) **Have your tool repaired only by qualified specialist personnel and only with original spare parts.** *This ensures that the tool safety is maintained.*
- a) **If the supply cord is damaged, it must be replaced by the manufacturer or it's service agent or a similarly qualified person in order to avoid a safety hazard.**

### Health protection



Danger

**Caution! Wear breathing equipment: Paint mist and solvent vapors are damaging to health. Always wear breathing equipment and only work in well ventilated rooms or using supplementary ventilating equipment. It is advisable to wear working clothing, safety glasses, ear protection and gloves**

### Flammable materials



Danger

**Do not use the spray guns to spray flammable substances.**



## Explosion protection

Do not use the unit in work places which are covered to the explosion protection regulations.



## Danger of explosion and fire through sources of flame during spraying work

There may be no sources of flame such as, for example, open fires, smoking of cigarettes, cigars or tobacco pipes, sparks, glowing wires, hot surfaces, etc. in the vicinity.



## Electrostatic charging (formation of sparks or flame)

Under certain circumstances, electrostatic charging can occur on the unit due to the rate of flow of the coating material when spraying. On discharging this can result in the emergence of sparks or fire. It is therefore necessary that the unit is always earthed through the electrical installation. The connection must take place through a correctly earthed two-pole-and-earth socket outlet.



## Ventilation

Good natural or artificial ventilation must be ensured in order to avoid the risk of explosion or fire and damage to health during spray work.

## Secure device and spray gun

All hoses, fittings, and filter parts must be secured before operating spray pump. Unsecured parts can eject at great force or leak a high pressure fluid stream causing severe injury.

Always secure the spray gun when mounting or dismantling the nozzle and in case of interruption to work.

## Recoil of spray gun

In case of high operating pressure, pulling the trigger can effect a recoil force of up to 15 N. If you are not prepared for this, your hand can be thrust backwards or your balance lost. This can lead to injury. Continuous stress from this recoil can cause permanent damage to health.



## Max. operating pressure

Max. permissible operating pressure for spray gun, spray gun accessories and high-pressure hose may not fall short of the maximum operating pressure of 200 bar (20 MPa) stated on the unit.

## Coating substance

Caution against dangers that can arise from the sprayed substance and observe the text and information on the containers or the specifications given by the substance manufacturer.

Do not spray any liquid of unknown hazard potential.

## High-pressure hose (safety note)

Attention, danger of injury by injection! Wear and tear and kinks as well as usage that is not appropriate to the purpose of the device can cause leakages to form in the high-pressure hose. Liquid can be injected into the skin through a leakage.



High-pressure hoses must be checked thoroughly before they are used.

Replace any damaged high-pressure hose immediately.

Never repair defective high-pressure hoses yourself!

Avoid sharp bends and folds: the smallest bending radius is about 20 cm.

Do not drive over the high-pressure hose. Protect against sharp objects and edges.

Never pull on the high-pressure hose to move the device.

Do not twist the high-pressure hose.

Do not put the high-pressure hose into solvents. Use only a wet cloth to wipe down the outside of the hose.

Lay the high-pressure hose in such a way as to ensure that it cannot be tripped over.

Electrostatic charging of spray guns and the high-pressure hose is discharged through the high-pressure hose. For this reason the electric resistance between the connections of the high-pressure hose must be equal or lower than 197 kΩ/m (60 kΩ/ft.).



For reasons of function, safety and durability, only use genuine WAGNER high-pressure hoses and spray nozzles. For overview see „Spare parts lists“.



The risk of damage rises with the age of the high-pressure hose. Wagner recommends replacing high-pressure hoses after 6 years.

### Connecting the device

A properly earthed socket outlet with earthing contact must be used for connection. The connection must be equipped with a residual current protective device with INF ≤ 30 mA.

### Setting up the unit



Danger

When working indoors:

Vapors containing solvents may not be allowed to build up in the area of the device.

Setting up the unit on the side a way from the sprayed object.

A minimum distance of 5 m between the unit and spray gun is to be maintained.

When working outdoors:

Vapors containing solvents may not be allowed to blow toward the unit.

Note the direction of the wind.

Set the unit up in such a way that vapors containing solvents do not reach the unit and build up there.

A minimum distance of 5 m between the unit and spray gun is to be maintained.

### Maintenance and repairs



Danger

Before carrying out any work on the device, relieve the pressure and unplug the power plug from the socket.

### Cleaning the unit



Danger

Danger of short circuit through penetrating water!

Never spray down the unit with high-pressure or high-pressure steam cleaners.

### Cleaning units with solvents



Danger

When cleaning the unit with solvents, the solvent should never be sprayed or pumped back into a container with a small opening (bunghole). An explosive gas/air mixture can be produced. The container must be earthed.

Do not use flammable materials for cleaning purposes.

### Earthing of the object

The object to be coated must be earthed.

### Thermal release

The device is equipped with a thermal release which disconnects the device in case of overheating. In this case switch the device off, turn the selector switch to the PRIME position (vertical), remove the mains plug and allow device to cool down for min. 30 minutes. Eliminate the cause of heating, e.g. slots for air intake covered.

Description (Fig. 1)

1 Pressure regulator	2 Hose connection
3 Inlet valve pusher	4 Carry handle
5 Nozzle holder	6 Spray Gun
7 Nozzle 517	8 Filter (white)*
9 ON / OFF Switch (0 = OFF, I = ON)	10 Selector switch
11 High-pressure hose	12 Return line
13 Inlet filter	14 Suction hose
15 Operating instructions	16 Oil
17 Pressure gauge	

\* filter pre-installed in gun

## Coating Materials Suitable for Use

Dispersion and latex paints for interior use.



The following coatings can only be used together with optional accessories (nozzle and filter) Water-based and solvent-containing lacquers and glazes. Paints, oils, release agents, synthetic enamels, PVC lacquers, undercoats, base coats, fillers and anti-rust paints.

## Coating Materials Not Suitable for Use

Materials that contain highly abrasive components, **facade paint**, caustic solutions and acidic coating substances.

Flammable materials



In order to ensure compatibility of the coating substance with the materials used to manufacture the device, please contact Wagner Service in cases of doubt.

## Field of application

Coating interior walls and outside objects (e.g. garden fences, garage doors, etc.).

## Required tools and auxiliary material

- Adjustable wrench (2 pcs.)
- Empty container
- A large piece of cardboard
- Covering material

## Preparation of the workplace



**Sockets and plugs must be masked. Risk of an electric shock as a consequence of sprayed material entering the socket!**



**Mask all the areas and objects that are not to be spray painted, or remove them from the work area. No liability is assumed for damage due to overspray.**

Danger

**Silicate paint corrodes glass and ceramic surfaces upon contact! All such surfaces must therefore be completely covered.**



Pay attention to the quality of the adhesive tape used. Do not use excessively strong adhesive tape on wallpaper and painted surfaces, in order to avoid damaging these surfaces when removing the tape. Remove adhesive tape slowly and evenly; do not use jerky movements. Do not leave adhesive tape on surfaces any longer than necessary, in order to minimise the possibility of residues when removing. Also observe the adhesive tape manufacturer's instructions.

## Preparation of the Coating Material

Using PowerPainter 90 interior wall paints, varnishes and glazes can be applied by spraying without diluting them, or by diluting them slightly. Detailed information is available in the technical data sheet of the manufacturer (→ Internet download).

1. Stir the material thoroughly and dilute it in the container as per the recommended dilution (an agitator is recommended for stirring).

### Thinning recommendation

Sprayed material	
Glazes	undiluted
Wood preservatives containing solvents or based on water, mordants, oils, disinfection agents, plant protective agents	undiluted
Paints containing solvents and watersoluble paints, primers, vehicle coating paints, thick-film glazes	dilute by 5 - 10 %
Interior wall paint (dispersions and latex paint)	dilute by 0-10 %



The values in the table are reference values. Find out how much the paint needs to be thinned by testing it. Details on how to test the spray paint can be found in the section called "Spray Technique".

## Assembly

1. Remove the protective covers on the hose and hose connection. (Fig. 2)
2. Screw the pressure gauge to the hose connection.
3. Screw the high pressure hose onto the pressure gauge.  
Keep hold of the connection using an adjustable spanner and tighten the hose connection with another spanner. (Fig. 3)
4. Screw the thread at the other end of the hose to the spray gun connection. Keep hold of the spray gun by applying an adjustable spanner to the handle and tighten the hose nut using another spanner. (Fig. 4)
5. Place the nozzle holder on the spray gun (Fig. 5A ) and rotate it into the final position (Fig. 5B), in order to fix it.
6. Pull the red shutter out of the paint entry point. (Fig. 6, 1)
7. Connect the suction hose to the paint entry point and secure into position. (Fig. 6, 2 and 3)
8. Push the return line on to the return flow connector. (Fig. 7)

## Control elements on the device (Fig. 8)

- A** The ON/OFF switch turns the power to the sprayer on and off (0=OFF, I=ON).
- B** The following settings can be made with the selector switch:
- |                                 |   |   |
|---------------------------------|---|---|
| PRIME (Switch set vertically)   | → | •For prefilling the system with paint<br>•For pressure relief |
| SPRAY (Switch set horizontally) | → | •For using the spray gun                                      |
- C** The pressure of the spray is set by the pressure regulator.  
The correct spray pressure depends on the paint being used.

## Spray Gun



Danger

**Always lock the trigger off when attaching the spray nozzle or when the spray gun is not in use.**

- To lock the trigger, push in the trigger lock from left to right, when looking at the rear of the gun. (Fig. 9, A)
- To unlock the trigger, push the trigger lock from right to left, when looking at the rear of the gun. (Fig. 9, B)
- Insert the nozzle with the tip pointing forwards. (Fig. 10)



Another nozzle size and gun filter must be used, depending on the material to be processed.  
Information about all the available nozzles and filters can be found in the section about "Accessories".

## Pressure Relief Procedure



Danger

**Be sure to follow the Pressure Relief Procedure when shutting the unit off for any purpose.  
This procedure relieves the pressure from the spray hose and the gun.**

1. Secure the spray gun. (Fig. 9, A)
2. Switch the device off.  
Turn the switch into the PRIME position (vertical). (Fig. 11)
3. Release the spray gun. Hold the spray gun over an empty container and press the trigger to relieve the pressure.
4. Secure the spray gun.

## Start-up

**Before connecting to the mains supply, be sure that the supply voltage is identical with the value given on the rating plate.**

1. Spray a little oil out of the provided flask into the marked opening (fig. 12, 1). Tip: tilt the device back.  
Light household oil can be substituted if necessary.
2. Disconnect the return flow pipe from the suction hose.
3. Place the suction hose (Fig. 12, 2) in the material container and the return line (Fig. 12, 3) in an empty container.
4. Press the red inlet valve pusher to ensure that the inlet valve is free. (Fig. 13)
5. Plug in the power cable.
6. Turn the switch into the PRIME position (vertical).
7. Hold the return line over the empty container and switch the device on.  
This will flush out any preservative remaining in the system.
8. Switch the device off again as soon as material emerges from the return line.

9. Fix the return line using the suction hose clips. (Fig. 14)
10. Turn the switch to the SPRAY position (horizontal).
11. Aim the spray gun at a piece of cardboard and switch the device on.
12. Release the spray gun and hold the trigger until the material emerges evenly.
13. Let go of the trigger and secure the spray gun.

## Spray Technique



**Be sure to follow the Pressure Relief Procedure when shutting the unit off for any purpose. This procedure relieves the pressure from the spray hose and the gun.**

**Be sure that the paint hose is free of kinks and clear of objects with sharp cutting edges.**

- It is best to practise on cardboard or a similar surface first of all, in order to check the spray pattern and become accustomed to using the spray gun.



If the paint sprays evenly, as shown in fig. 15 A, all the setting must be correct.

If the paint looks stripy after spraying, as shown in fig. 15 B, gradually increase the pressure, or dilute more in 5% steps (please note the maximum amount of thinner stipulated by manufacturer.)

- The key to obtaining a high quality result is even coating of the entire surface. Keep your arm moving at a constant speed and keep the spray gun at a constant distance from the surface. The best spraying distance is approx. 25 to 30 cm between the spray nozzle and the surface. (Fig. 16, A)
- Keep the spray gun at right angles to the surface. This means moving your entire arm back and forth rather than just flexing your wrist. (Fig. 16, B)
- Keep the spray gun perpendicular to the surface, otherwise one end of the pattern will be thicker than the other. (Fig. 16, C)
- Trigger gun after starting the stroke. Release the trigger before ending the stroke. (Fig. 16, D) The spray gun should be moving when the trigger is pulled and released. Overlap each stroke by about 30%. This will ensure an even coating.



During operation the pump switches on and off continuously, in order to regulate the pressure. This is normal and is not a malfunction.

## Unclogging the Spray nozzle

If the spray pattern becomes distorted or stops completely while the gun is triggered, follow these steps.



**Do not attempt to unclog or clean the nozzle with your finger. High pressure fluid can cause injection injury.**

1. Release the trigger and secure the gun. Rotate the reversible nozzle arrow 180° so that the point of the arrow is toward the rear of the gun. (Fig. 17).



Under pressure, the nozzle may be very difficult to turn. Turn the switch to the PRIME position (vertical) and pull the trigger. This will relieve pressure and the tip will turn more easily.

2. Turn the switch to the SPRAY position (horizontal).
3. Unlock the gun and squeeze the trigger, pointing the gun at a scrap piece of wood or cardboard. This allows pressure in the spray hose to blow out the obstruction. When the nozzle is clean, material will come out in a straight, high pressure stream.
4. Release the trigger and secure the gun. Reverse the nozzle so the arrow points forward again. Unlock the gun and resume spraying.

## Interruption of Work



**Be sure to follow the Pressure Relief Procedure when shutting the unit off for any purpose. This procedure relieves the pressure from the spray hose and the gun.**

- Switch the device off and remove the power plug.
- Put the spray gun in a plastic bag and seal so that it is air-tight.
- Wet paint surface in paint container with a little water to prevent a skin from forming.

## Taking Out of Operation and Cleaning

Proper cleaning is the prerequisite for problem-free operation of the paint application device. No warranty claims are accepted in case of improper or no cleaning.



**Do not use flammable materials for cleaning purposes.**



Always clean the device as soon as you have finished operation. Dried-on coating substance makes cleaning more difficult.

1. Perform Pressure Relief Procedure.
2. Secure the spray gun.
3. Remove the nozzle holder from the spray gun. (Fig. 18)
4. Put the suction hose and return flow pipe into a container full of water or suitable cleaning solution.
5. Turn the switch to the SPRAY position and set maximum pressure.
6. Hold the spray gun at the edge of an empty container. (Fig. 19)



**Earth the gun when flushing with solvents using a metal container.**

7. Release the gun and keep the trigger pressed until only clear liquid emerges from the gun.
8. Switch the device off and remove the power plug.
9. Turn the switch into the PRIME position (vertical).
10. Pull the trigger to relieve the pressure.
11. Secure the spray gun.
12. Remove spray gun from the paint hose using adjustable wrenches.
13. Unclip the top of the trigger guard (fig. 20, 1) from the gun head.
14. Using the bottom of the trigger guard as a wrench, loosen and remove the handle assembly (fig. 20, 2) from the gun head.
15. Remove the gun filter (fig. 20, 3). Clean it and the nozzle with a soft brush and a suitable detergent.
16. Remove the nozzle (1), plain washer (2) and the mounting (3) from the nozzle holder (4) and clean all parts thoroughly. (Fig. 21)
17. Replace the cleaned filter (fig. 20, 3) in the gun housing with the conical side forwards and screw the gun housing to the spray gun again.
18. Replace the mounting and the plain washer in the nozzle holder.  
Screw the nozzle holder onto the gun.
19. Detach the suction hose from the basic unit.
20. Disconnect the return line by pushing the blue lock ring upwards and pulling the hose downwards at the same time.
21. Wipe off the exteriors of both hoses.
22. Carefully remove the filter disc (fig. 22, 1) from the suction filter using pliers.
23. Clean the filter disk thoroughly under running water.
24. Remove the high pressure hose from the basic unit with a wrench.
25. Pour approx. 60 ml oil into the pump as a preservative. (Fig. 23)
26. Insert the power plug.
27. Hold a cloth in front of the hose connection and switch the device on for approx. 5 seconds. (Fig. 24)  
This procedure preserves the pump.

## Maintenance and repairs



**Before carrying out any work on the device, relieve the pressure and unplug the power plug from the socket.**

### a) Cleaning the inlet valve



If any problems occur when the paint is sucked up, the intake valve needs to be cleaned or serviced. Problems can be avoided by cleaning and servicing the device properly.

1. Remove the suction hose and return tube.
2. Remove the inlet valve unit (fig. 25, 1) from the basic unit with an adjustable wrench. Visually inspect the inside and outside of the inlet valve assembly. Clean any paint residue with the appropriate cleaning solution.
3. Replace inlet valve assembly by screwing it into the sprayer.



**b) Servicing the pump**
**Repair kits (Fig. 26)**

Description	Order No.
Repair kit for piston pump (Pos. 5,6,7,8,9,10,11)	2325 023
Repair kit for seals (Pos. 8,9)	2324 303

**Danger**

**Always wear protective eye wear while servicing the pump. Be sure to follow the Pressure Relief Procedure when shutting the unit down for any purpose, including servicing or adjusting. After performing the Pressure Relief Procedure, be sure to unplug the unit before servicing or adjusting. Area must be free of solvents and paint fumes.**

1. Remove the suction hose and return tube.
2. Remove the front cover and the 4 screws that secure it using a T20 Torx head driver.
3. Remove the yoke screw (1) and washer (2) that secures the dowel pin (3). The dowel pin connects the yoke (4) to the piston (5).
4. Using a pliers, pull the dowel pin out.
5. Rotate the pump shaft so the piston is in the top dead center position. Press the yoke (4) against the top nut (7) with a screwdriver, for example. This is required to disassemble all the parts.
6. Unscrew the inlet valve unit (6) from the basic unit.
7. Remove the piston unit by pushing the piston (5) downwards.
8. Check the piston (5) and the seal unit (9) for wear and tear and replace parts if necessary.
9. Unscrew and remove the top nut (7) using an adjustable wrench.
10. Remove the upper seal (8) by pushing against the seal. Be sure not to scratch the housing where the seals are located.
11. Clean the area where the new seals are to be installed.

**Assembly**

1. Lubricate the new top seal (8) with Separating Oil or light household oil and by hand place the seal (with the open side facing down) into the top port of the housing.
2. Take the new top nut (7) and apply some lubricant to the threads. Place the top nut into the top of the housing and tighten with an adjustable wrench. This will drive the top seal into the correct position.
3. Lubricate the piston (5) and the seal unit (9) as described for the upper seal. Install the piston and seal unit in the lower part of the housing.
4. Insert the insertion tool (10) and turn it firmly into the respective position, ensuring that the piston and seal are installed correctly. Remove the insertion tool.
5. Align the piston (5) with the yoke (4). Be careful not to damage the piston.
6. Apply a bearing grease to the holes in the yoke where the dowel (3) is inserted.
7. Install the dowel pin (3) to connect the yoke to the piston. The piston may have to be moved up or down to do this.
8. Install the yoke screw (1) and washer (2) to secure the dowel pin.
9. Install the new O-ring (11) on the inlet valve assembly, lubricate with Separating Oil or light household oil, thread into the bottom (inlet) of the housing, and tighten with an adjustable wrench.
10. Apply a few drops of Separating Oil or light household oil between the top nut (7) and piston (5). This will prolong the seal life.
11. Install front cover and 4 screws.

**Spare Parts List (Fig. 27)**

Pos.	Description	Order No.
1	Spray gun assembly	538040
2	Suction hose and Return line	2306606
3	High-pressure hose, 15 m, yellow	2390608
4	Pressure gauge	2383995

**Accessories (not included in the delivery)**

Description	Order No.
Nozzle 211 (20° spray angle, 0,011 inch nozzle diameter)	554211
Nozzle 311 (30° spray angle, 0,011 inch nozzle diameter)	554311
Nozzle 411 (40° spray angle, 0,011 inch nozzle diameter)	554411
Nozzle 213 (20° spray angle, 0,013 inch nozzle diameter)	554213
Nozzle 313 (30° spray angle, 0,013 inch nozzle diameter)	554313
Nozzle 413 (40° spray angle, 0,013 inch nozzle diameter)	554413
Nozzle 415 (40° spray angle, 0,015 inch nozzle diameter)	554415

**Accessories (not included in the delivery)**

Nozzle 515 (50° spray angle, 0,015 inch nozzle diameter)	554515
Nozzle 615 (60° spray angle, 0,015 inch nozzle diameter)	554615
Nozzle 417 (40° spray angle, 0,017 inch nozzle diameter)	554417
Nozzle 517 (50° spray angle, 0,017 inch nozzle diameter)	554517
Nozzle 617 (60° spray angle, 0,017 inch nozzle diameter)	554617
Nozzle 519 (50° spray angle, 0,019 inch nozzle diameter)	554519
Nozzle 619 (60° spray angle, 0,019 inch nozzle diameter)	554619
Filter, red (nozzle 211/311/411/213/313/413, 1 pack)	34383
Filter, red (nozzle 211/311/411/213/313/413, 10 pack)	97022
Filter, yellow (nozzle 415/515/615, 1 pack)	43235
Filter, yellow (nozzle 415/515/615, 10 pack)	97023
Filter, white (nozzle 417/517/617/519/619, 1 pack)	34377
Filter, white (nozzle 417/517/617/519/619, 10 pack)	97024
Gun extension (15 cm)	556074
Gun extension (30 cm)	556075
Gun extension (45 cm)	556076
Gun extension (60 cm)	556077
Gun extension with slewable knee joint (100 cm)	96015
Gun extension with slewable knee joint (200 cm)	96016
Gun extension with slewable knee joint (300 cm)	96017
Inline Roller IR-100	345010
High-pressure hose DN 4 mm, 7,5 m with stainless steel nipple	9984573
High-pressure hose DN 6 mm, 15 m for dispersion	9984574
High-pressure hose DN 6 mm, 30 m for dispersion	9984575
Double socket for coupling highpressure hoses (1/4" x 1/4")	34038
Metex-Reuse: Reuse for pre-filtering of coating material in vessel. Place suction pipe in the reuse.	34950
Sieve package (5 pcs) for paint	34952
Sieve package (5 pcs) for dispersion	34951
Easy Glide (118 ml)	0508619

Further information about the WAGNER range of products for renovating is available under [www.wagner-group.com](http://www.wagner-group.com)

**Technical Data**

Pump type	Piston pump
Power source	230 V ~ 50 Hz
Power consumption	800 W
Fusing	Only connect to sockets protected with an FI fuse (16 A)
Protection class	I
Max. spray pressure	20 MPa (200 bar)
Max. delivery rate	1.9 l/min
Volume flow at 12 MPa (120 bar) with water	1.6 l/min
Sound pressure level*	75 dB (A) Uncertainty K= 4 db
Sound pressure output*	88 dB (A) Uncertainty K= 4 db
Oscillation level*	< 2.5 m/s <sup>2</sup> Uncertainty K= 1.5 m/s <sup>2</sup>
Max. temperature of coating substance	40°C
Max. nozzle size	0.019
Hose length	15 m
Product dimensions	approx. 40 x 29 x 44 cm
Weight	approx. 10.2 kg

\* Measured in accordance with EN 50580:2014

**Information about the oscillation level**

The specified oscillation level has been measured according to a standard test procedure and can be used to compare against

electric tools.

The oscillation level is also for determining an initial assessment of the vibrational strain.

**Attention!** The vibration emission value can differ from the specified value when the electric tool is actually in use, depending on how the electric tool is being used. It is necessary to specify safety measures to protect the operating personnel. These measures are based on an estimated shutdown during the actual conditions of use (all parts of the operating cycle are taken into consideration here, for example periods when the electric tool is switched off, and, when it is switched on but running without any load).

**Environmental protection**



The device and all accessories and packaging have to be recycled in an environmentally friendly manner. Do not dispose of the appliance with household waste. Support environmental protection by taking the appliance to a local collection point or obtain information from a specialist retailer. Leftover paint and solvents may not be emptied into drains, the sewage system or disposed of as household rubbish. It has to be disposed of separately as special waste. Please pay special attention to the instructions on the product packaging.

**Important Note regarding Product Liability!**

Due to an EC ordinance in effect since 01.01.1990, the manufacturer is liable for his product only if all parts originate from or were approved by the manufacturer and the devices are assembled and operated correctly. The use of other accessories and spare parts can partially or completely invalidate the liability.

**Correction of Malfunctions**

Problem	Cause	Remedy
The sprayer does not start.	<ul style="list-style-type: none"> <li>• The sprayer is not plugged in.</li> <li>• The device is switched off.</li> <li>• The sprayer was turned off while still under pressure.</li> <li>• No voltage is coming from the wall plug.</li> <li>• The extension cord is damaged or has too low a capacity.</li> <li>• Device overheated</li> </ul>	<ul style="list-style-type: none"> <li>→ Plug the sprayer in.</li> <li>→ Turn the ON/OFF switch to ON.</li> <li>→ Perform pressure relief procedure and set selector switch back to SPRAY</li> <li>→ Properly test the power supply voltage.</li> <li>→ Replace the extension cord.</li> </ul> <ul style="list-style-type: none"> <li>→ Switch the device off, turn the selector switch to the PRIME position (vertical), remove the mains plug and allow device to cool down for min. 30 minutes. Eliminate the cause of overheating, e.g. covered ventilation slot.</li> <li>→ Please contact Wagner Service</li> </ul>
The spray device runs but does not suck up any paint when the selector switch is set to the PRIME position.	<ul style="list-style-type: none"> <li>• The unit will not prime properly or has lost prime.</li> <li>• The paint bucket is empty or the suction tube is not totally immersed in the paint.</li> <li>• The suction tube is clogged.</li> <li>• The suction tube is loose at the inlet valve.</li> <li>• The inlet valve is stuck.</li> </ul>	<ul style="list-style-type: none"> <li>→ Try to prime the unit again.</li> </ul> <ul style="list-style-type: none"> <li>→ Refill the bucket or immerse the suction tube in paint.</li> <li>→ Clean the suction tube.</li> <li>→ Tighten it securely.</li> <li>→ Press the inlet valve pusher. If the problem is not solved, clean the inlet valve.</li> <li>→ Replace</li> <li>→ Please contact Wagner Service</li> </ul>
The sprayer draws up paint but the pressure drops when the gun is triggered.	<ul style="list-style-type: none"> <li>• The spray nozzle is worn.</li> <li>• The inlet filter is clogged.</li> <li>• The gun filter is plugged.</li> </ul>	<ul style="list-style-type: none"> <li>→ Replace the spray nozzle with a new nozzle.</li> <li>→ Clean the inlet filter.</li> <li>→ Clean or replace the filter. Always keep extra filters on hand.</li> </ul> <ul style="list-style-type: none"> <li>• The paint is too viscous or contaminated.</li> <li>• The inlet valve is worn or damaged.</li> </ul> <ul style="list-style-type: none"> <li>→ Thin or strain the paint.</li> <li>→ Replace</li> </ul>
The spray gun leaks	<ul style="list-style-type: none"> <li>• Internal parts of the gun are worn or dirty.</li> </ul>	<ul style="list-style-type: none"> <li>→ Please contact Wagner Service</li> </ul>
The nozzle assembly leaks	<ul style="list-style-type: none"> <li>• The nozzle was assembled incorrectly.</li> <li>• A seal is dirty.</li> </ul>	<ul style="list-style-type: none"> <li>→ Check the tip assembly and assemble properly</li> <li>→ Clean the seal.</li> </ul>
The spray gun will not spray.	<ul style="list-style-type: none"> <li>• The spray nozzle or the gun filter is plugged.</li> <li>• The spray tip is in the reverse position.</li> </ul>	<ul style="list-style-type: none"> <li>→ Clean the spray nozzle or gun filter.</li> <li>→ Put the nozzle in the forward position.</li> </ul>

Problem	Cause	Remedy
The paint pattern is tailing.	<ul style="list-style-type: none"> <li>• The paint is too viscous or contaminated.</li> <li>• The spray nozzle or the gun filter is plugged.</li> <li>• The spray nozzle is worn.</li> <li>• The inlet filter is clogged.</li> <li>• The gun filter is plugged.</li> </ul> <ul style="list-style-type: none"> <li>• The inlet valve is worn or damaged.</li> </ul>	<ul style="list-style-type: none"> <li>→ Thin or strain the paint.</li> <li>→ Clean the spray nozzle or gun filter.</li> <li>→ Replace the spray nozzle with a new nozzle.</li> <li>→ Clean the inlet filter.</li> <li>→ Clean or replace the filter. Always keep extra filters on hand.</li> <li>→ Replace</li> </ul>

## GUARANTEE DECLARATION

(Status 01.02.2009)

### 1. Scope of guarantee

All Wagner professional colour application devices (hereafter referred to as products) are carefully inspected, tested and are subject to strict checks under Wagner quality assurance. Wagner exclusively issues extended guarantees to commercial or professional users (hereafter referred to as "customer") who have purchased the product in an authorised specialist shop, and which relate to the products listed for that customer on the Internet under

[www.wagner-group.com/profi-guarantee](http://www.wagner-group.com/profi-guarantee).

The buyer's claim for liability for defects from the purchase agreement with the seller as well as statutory rights are not impaired by this guarantee.

We provide a guarantee in that we decide whether to replace or repair the product or individual parts, or take the device back and reimburse the purchase price. The costs for materials and working hours are our responsibility. Replaced products or parts become our property.

### 2. Guarantee period and registration

The guarantee period amounts to 36 months. For industrial use or equal wear, such as shift operations in particular, or in the event of rentals it amounts to 12 months.

Systems driven by petrol or air are also guaranteed for a 12 month period.

The guarantee period begins with the day of delivery by the authorised specialist shop. The date on the original purchase document is authoritative.

For all products bought in authorised specialist shops from 01.02.2009 the guarantee period is extended to 24 months providing the buyer of these devices registers in accordance with the following conditions within 4 weeks of the day of delivery by the authorised specialist shop.

Registration can be completed on the Internet under [www.wagner-group.com/profi-guarantee](http://www.wagner-group.com/profi-guarantee).

The guarantee certificate is valid as confirmation, as is the original purchase document that carries the date of the purchase. Registration is only possible if the buyer is in agreement with having the data being stored that is entered during registration.

When services are carried out under guarantee the guarantee period for the product is neither extended nor renewed.

Once the guarantee period has expired, claims made against the guarantee or from the guarantee can no longer be enforced.

### 3. Handling

If defects can be seen in the materials, processing or performance of the device during the guarantee period, guarantee claims must be made immediately, or at the latest within a period of 2 weeks.

The authorised specialist shop that delivered the device is entitled to accept guarantee claims. Guarantee claims may also be made to the service centres named in our operating instructions. The product has to be sent without charge or presented together with the original purchase document that includes details of the purchase date and the name of the product. In order to claim for an extension to the guarantee, the guarantee certificate must be included.

The costs as well as the risk of loss or damage to the product in transit or by the centre that accepts the guarantee claims or who delivers the repaired product, are the responsibility of the customer.

### 4. Exclusion of guarantee

Guarantee claims cannot be considered

–for parts that are subject to wear and tear due to use or other natural wear and tear, as well as defects in the product that are a result of natural wear and tear, or wear and tear due to use. This includes in particular cables, valves, packaging, jets, cylinders, pistons, means-carrying housing components, filters, pipes, seals, rotors, stators, etc. Damage due to wear and tear that is caused in particular by sanded coating materials, such as dispersions, plaster, putty, adhesives, glazes, quartz foundation.

–in the event of errors in devices that are due to non-compliance with the operating instructions, unsuitable or unprofessional use,

incorrect assembly and/or commissioning by the buyer or by a third party, or utilisation other than is intended, abnormal ambient conditions, unsuitable coating materials, unsuitable operating conditions, operation with the incorrect mains voltage supply/frequency, over-operation or defective servicing or care and/or cleaning.

- for errors in the device that have been caused by using accessory parts, additional components or spare parts that are not original Wagner parts.
- for products to which modifications or additions have been carried out.
- for products where the serial number has been removed or is illegible
- for products to which attempts at repairs have been carried out by unauthorised persons.
- for products with slight deviations from the target properties, which are negligible with regard to the value and usability of the device.
- for products that have been partially or fully taken apart.

**5. Additional regulations.**

The above guarantees apply exclusively to products that have been bought by authorised specialist shops in the EU, CIS, Australia and are used within the reference country.

If the check shows that the case is not a guarantee case, repairs are carried out at the expense of the buyer.

The above regulations manage the legal relationship to us conclusively. Additional claims, in particular for damages and losses of any type, which occur as a result of the product or its use, are excluded from the product liability act except with regard to the area of application.

Claims for liability for defects to the specialist trader remain unaffected.

German law applies to this guarantee. The contractual language is German. In the event that the meaning of the German and a foreign text of this guarantee deviate from one another, the meaning of the German text has priority.

J. Wagner GmbH  
 Division Professional Finishing  
 Otto Lilienthal Strasse 18  
 88677 Markdorf  
 Federal Republic of Germany

Subject to modifications

**Warning**

If the supply cord of this appliance is damaged, it must only be replaced by a repair shop appointed by the manufacturer, because special purpose tools are required.

The wires in this mains lead are coloured in accordance with the following code:

**green/yellow = earth**      **blue = neutral**  
**brown = live**

As the colours of the wires in the mains lead of this appliance may not correspond with the coloured markings identifying the terminals in your plug, proceed as follows:

- The wire which is coloured green and yellow must be connected to the terminal in the plug which is marked with the letter E or by the earth symbol or coloured green or green and yellow.
- The wire which is coloured blue must be connected to the terminal which is marked with the letter N or coloured black.
- The wire which is coloured brown must be connected to the terminal which is marked with the letter L or coloured brown.
- Should the moulded plug have to be replaced, never re-use the defective plug or attempt to plug it into a different 13 A socket. This could result in an electric shock.
- Should it be necessary to exchange the fuse in the plug only use fuses approved by ASTA in accordance with BS 1362. Only 13 Amp fuses may be used.
- To ensure that the fuse and fuse carrier are correctly mounted please observe the provided markings or colour coding in the plug.
- After changing the fuse, always make sure that the fuse carrier is correctly inserted. Without the fuse carrier, it is not permissible to use the plug.
- The correct fuses and fuse carriers are available from your local electrical supplies stockist.

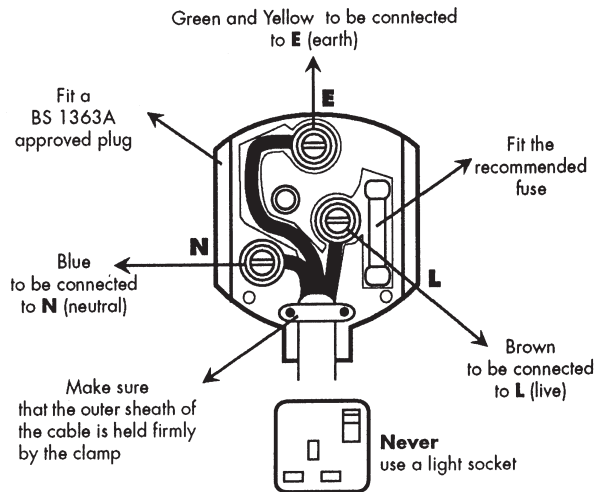

## EU Declaration of conformity

We declare under sole responsibility that this product conforms to the following relevant stipulations:

2006/42/EC, 2014/30/EU, 2011/65/EU, 2012/19/EU

Applied harmonised norms:

EN ISO 12100, EN 1953, EN 60204-1, EN 61000-3-2, EN 61000-3-3, EN 61000-6-1, EN 61000-6-3

The EU declaration of conformity is enclosed with the product.

If required, it can be re-ordered using order number **2389926**.